

BLT-Mxxxx & HKK-Dxxxx

EUR HUK

LED

| | M10 | BLT-M1000 |
|--|------|-----------|
| | M12 | BLT-M1200 |
| | DN15 | HKK-D1500 |

| EUR-096SxxxDT/DV/ST/SV | BLT-M1000 | HKK-D1500 |
|------------------------|-----------|-----------|
| EUR-150SxxxDT/DV/ST/SV | BLT-M1000 | HKK-D1500 |
| EUR-200SxxxDT/DV/ST/SV | BLT-M1000 | HKK-D1500 |
| EUR-240SxxxDT/DV/ST/SV | BLT-M1200 | HKK-D1500 |
| EUR-320SxxxDT/DV/ST/SV | BLT-M1200 | HKK-D1500 |
| HUK-096SxxxDT/DV | BLT-M1200 | HKK-D1500 |
| HUK-150SxxxDT/DV | BLT-M1200 | HKK-D1500 |

| | - | - | 20 kg | BLT-M1000 |
|--|---|-------|-------|-----------|
| | - | - | 20 kg | BLT-M1200 |
| | - | - | 20 kg | HKK-D1500 |
| | - | 105 g | - | BLT-M1000 |
| | - | 130 g | - | BLT-M1200 |
| | - | 40 g | - | HKK-D1500 |

| BLT-M1000 | 120 | M10 | / |
|-----------|-----|------|---|
| BLT-M1200 | 120 | M12 | / |
| HKK-D1500 | 120 | DN15 | / |

BLT-M1000

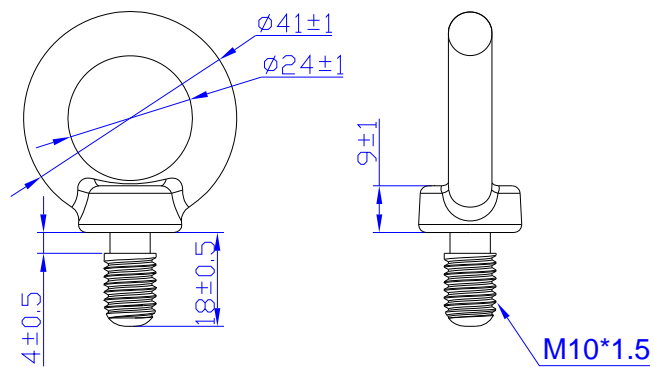

PROJ:

: ± 1

BLT-M1200

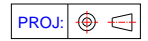
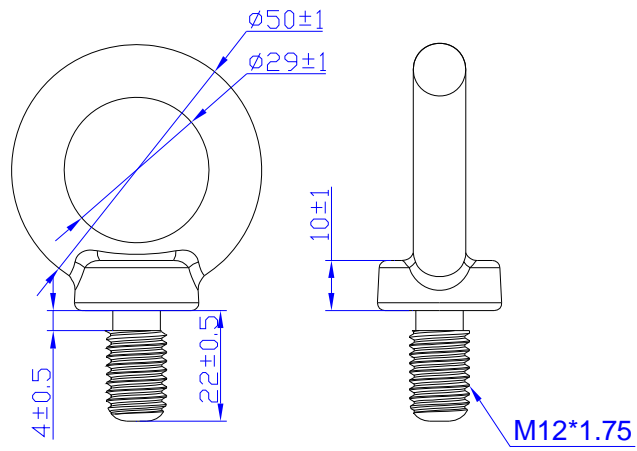

: ±1

HKK-D1500

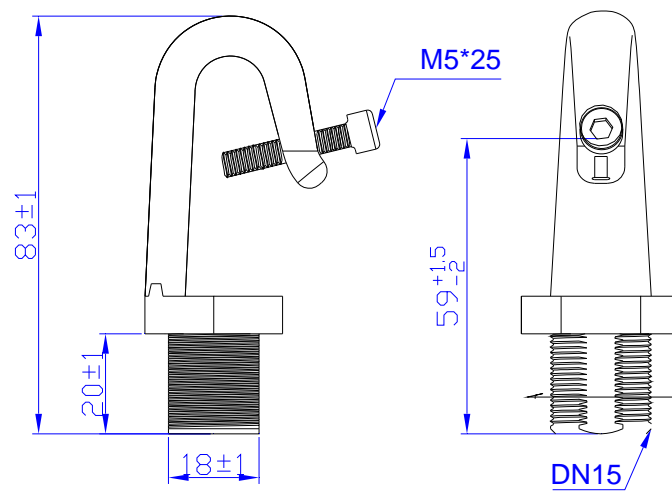

| | | | | |
|------------|---|--|---|---|
| | | | | |
| | | | | |
| 2018-08-24 | A | | / | / |